

Sdmay 18-06
Black & Veatch
Advisors: Dr. Ajarapu, Cole Beaulieu, Adam Literski
Andrew Brown
Gavin Christenson
Eric Fritz
Brent Hines
Weng Hoong Loo
sdmay18-06@iastate.edu
<http://sdmay18-06.sd.ece.iastate.edu>

Revised: 10-30-17/v2

138kV/ 13.8kV Substation

PROJECT PLAN

Contents

1 Introduction	2
1.1 Project statement	2
1.2 purpose	2
1.3 Goals	2
2 Deliverables	2
3 Design	3
3.1 Previous work/literature	3
3.2 Proposed System Block diagram	3
3.3 Assessment of Proposed methods	3
3.4 Validation	3
4 Project Requirements/Specifications	4
4.1 functional	4
4.2 Non-functional	4
4.3 Standards	4
5 Challenges	4
6 Timeline	5
6.1 First Semester	5
6.2 Second Semester	5
7 Conclusions	6
8 References	6
9 Appendices	7

1 Introduction

1.1 PROJECT STATEMENT

The purpose of this project is to design a 138kV / 13.8kV distribution substation that safely steps down voltage which is then sent to distribution lines where it will reach the consumer.

1.2 PURPOSE

A distribution substation steps high voltages from transmission lines down to lower voltages for distribution lines. The lower voltages of the distribution lines can be supplied to consumers in a safer format this way, however, 13.8kV is still a dangerous level. The voltage is stepped down through various transformers, lowering the current while raising the voltage. This complex system will involve several components including transformers(Current and Voltage), relays, circuit breakers, blades, and various panel arrangements.

1.3 GOALS

The goals for this senior design project are as follows:

- Design and refine a 138kV / 13.8kV substation one-line and three-line diagram
- Create a protection plan for the substation
- Plan the layout for the substation control house
 - Panel Layouts
 - Wiring Diagrams
- Create a final presentation of the design to be presented to Black & Veatch

2 Deliverables

To meet our goals for this project, we have the following list of deliverables:

- Develop a Gantt chart and man-hour budget for the project
 - Man-hour budget should track actual hours in comparison to predicted hours
- Based on the protective relay scheme identified by Black & Veatch:
 - System one-line diagram
 - System three-line diagram
 - Protection and control schematics
 - Wiring diagram and panel layouts
- Materials List
- Weekly teleconference with Black & Veatch
 - Weekly progress report & meeting minutes
 - Weekly meeting agenda in advance of meeting
- Project Design Review

- Final Presentation to Black & Veatch

3 Design

To design this substation, we are taking a preliminary one-line diagram provided by Black & Veatch and modifying it to suit our design needs. We will also create a three-line diagram from our final version of the one-line diagram, as well as a wiring diagram for the system protection and controls.

3.1 PREVIOUS WORK/LITERATURE

As common as distribution substations are in the world today, we have a lot of information at our disposal for this project. Black & Veatch is our primary source of information, and they have provided us with many preliminary drawings, as well as a PowerPoint explaining various concepts we can use for the one-line and three-line diagrams. Various documents have been provided from Black & Veatch which will help with the design process. These documents include templates of the key protection diagram, one-line diagram, three-line diagrams and AC-DC protection documents. A powerpoint on high voltage substations and previous senior design projects were given to us from our faculty advisor, which will also help the design process. Previous groups major problem was time-management. To overcome this problem, we will be implementing strict deadlines which we will stick to throughout the semester.

3.2 PROPOSED SYSTEM BLOCK DIAGRAM

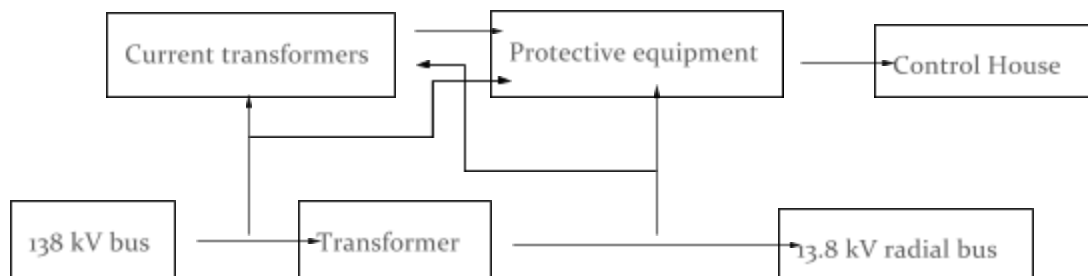

3.3 ASSESSMENT OF PROPOSED METHODS

We are taking an approach to our design project that involves laying out our schedule first with a Gantt chart and man-hour budget, and then creating one-line and three-line diagrams, wiring diagrams, panel layouts, and control schematics in AutoCAD. Since we are working with Black & Veatch, we are using an approach very similar to their own. We have finished our Key Protection Diagram, the document in which all other documents will be based off of. In this document, we specify the relays in which fault currents will travel.

3.4 VALIDATION

Since we will only be designing a substation, and not building it, we will be using our weekly teleconferences and final presentation with Black & Veatch to validate our design. Black & Veatch has a wealth of experience with distribution substations that we will be using not only for guidance,

but also for confirmation that our design project is successful. A deadline for each rough draft of every document will be set in order to receive proper feedback and validation in a timely fashion.

4 Project Requirements/Specifications

4.1 FUNCTIONAL

The technical requirements for this project include designing a distribution substation to convert 138kV to 13.8kV using a radial bus system, and the panel layout, protection and control schematics, and wiring diagrams that go along with it. All of the functional components for this project will be designed in AutoCAD.

4.2 NON-FUNCTIONAL

The biggest non-functional component of this project is weekly meetings with Black & Veatch via Google Hangout to provide updates on our progress, with meeting agendas beforehand and meeting minutes after. The other non-technical deliverables include a Gantt chart, man-hour budget, materials list, and final presentation to Black & Veatch.

4.3 STANDARDS

The standards for our design project are based on the 2014 NFPA National Electrical Code. I seriously doubt anything in our design project will be considered unethical, given the necessity for electrical power we have in today's society and the multitude of distribution substations that have already been built. The applicable standards for our project are those concerning electrical fire safety in the event of things like lightning strikes or equipment failure.

5 Challenges

The main challenge we are facing as a group is understanding the project material such as the key protection plan, one line diagram, and the protection schematics. The major reason for us facing this challenge is the project being complicated and bulky as it is a real world designing problem, as well as us having minimal knowledge about the material. Even if we manage to pull off the project it wouldn't mean anything to us if we don't understand the reasoning behind the decisions made while revising the drawings.

Hence, at times when we are could not figure out the materials at hand, we plan to consult multiple experts and resources in the field which includes our Senior Design Advisor Professor Ajjarapu, Black & Veatch Experts, National Electrical Code and of course researching through the internet.

Another challenge we will face is designing the AC-DC documents as well as the panel arrangements. These documents will be based off of the key protection diagram, as well as the project scope document which was provided by Black & Veatch. There will be a lot of cross referencing of these documents, for this will be key to completing our project in an efficient manor.

Besides that, another challenge that our group was facing is using AutoCAD to complete our designs. We are mostly new to AutoCAD, so we have a lot to learn for that portion of our project. However as time goes by, we get more and more familiar with the different functionality of autoCAD and the challenge is no longer a big threat anymore.

Cost and materials will not be a problem for us as this project is just a conceptual design together with our stakeholder, Black & Veatch. No cost implication as our main outcome of this project is to understand the basics on substations and the protection scheme as it is not as simple as just a stepping down transformer. Therefore, free CAD software available to us through Iowa State to omit the cost portion, and there will be no physical materials involved in the project.

6 Timeline

The timeline for our project is outlined in the following Gantt chart:

138/13.8 kV Substation Senior Design Project Gantt Chart



6.1 FIRST SEMESTER

For the first semester of our senior design project, we are developing a Gantt chart and man-hour budget for the project. We are also finalizing the one-line diagram of the substation, as well as our key protection plan for the substation. Lastly, we will be starting the three-line diagram of the substation and the schematics for protection and control.

6.2 SECOND SEMESTER

During the second semester of our design project we will be finalizing the three-line diagram of the substation, as well as the protection and control schematics. We will be developing a materials list for the project, and send our design to Black & Veatch for review. With feedback from Black &

Veatch, we will make any necessary changes to our design and create a presentation for Black & Veatch of our final design.

7 Conclusions

In conclusion, we are responsible for designing a substation and all the protection schemes, controls, wiring as whole so that we can truly understand the in depth details of designing a substation. The designing process includes us brainstorming and working together in a team to ensure fairness and the healthy balance of workload in the team. The design documents, which will be reviewed according to our standard reviewing procedure as mentioned before, will be used to ensure our design is of the best quality before finalizing it. At the very end of the project, we will showcase our final substation design to Black & Veatch and demonstrate our skills and knowledge along the way on working on this project.

8 References

References for this project includes but not limited to:

1. Key Protection Plan provided by Black & Veatch
2. One Line Diagram provided by Black & Veatch
3. University of Iowa State Senior Design Substation: System Protection Requirements provided by Black & Veatch
4. HV Substation Design Notes by Professor Ajjarapu
5. ANSI Standard Device Number List
6. 2014 NFPA National Electrical Code
7. IEEE HV Substation Design Presentation Slides

9 Appendices

One-line Diagram: -

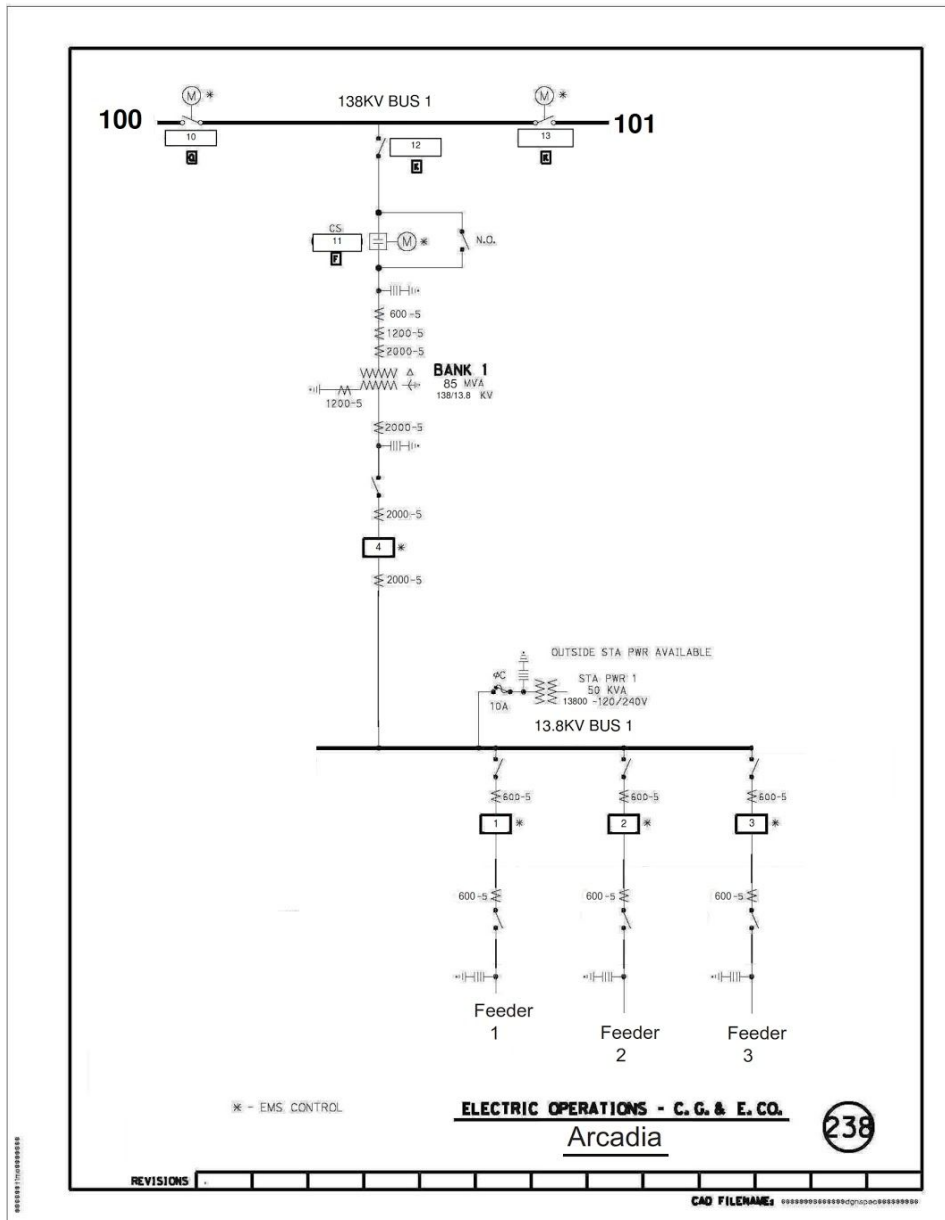

Key Protection Plan: -

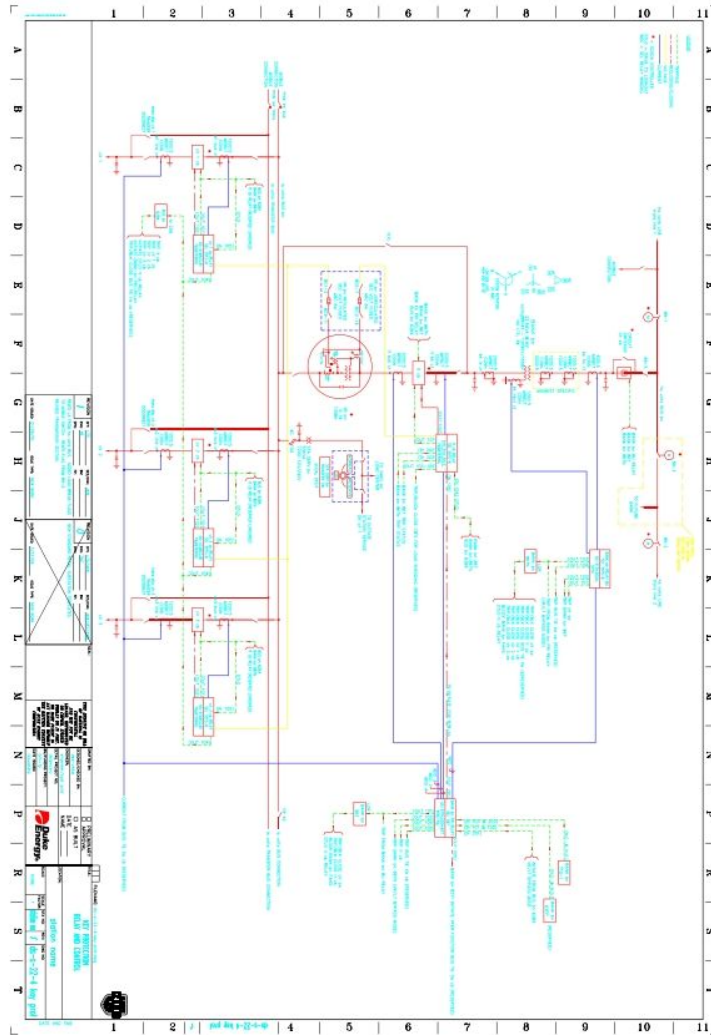

Primary Protection Circuit Diagram (from: University of Iowa State Senior Design Substation: System Protection Requirements provided by Black & Veatch): -

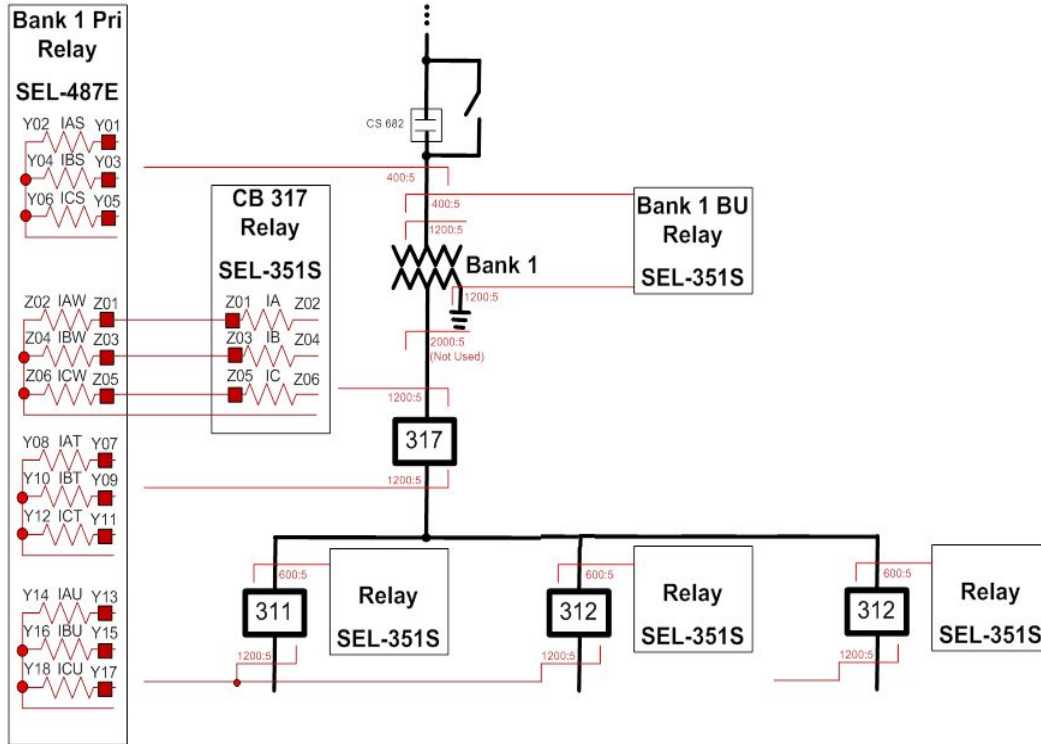

Communication Schematics (from: University of Iowa State Senior Design Substation: System Protection Requirements provided by Black & Veatch): -

